

REV.	ECN NO.	DESCRIPTION	DESIGN	DATE
A		INITIAL	Kai	2018.03.29

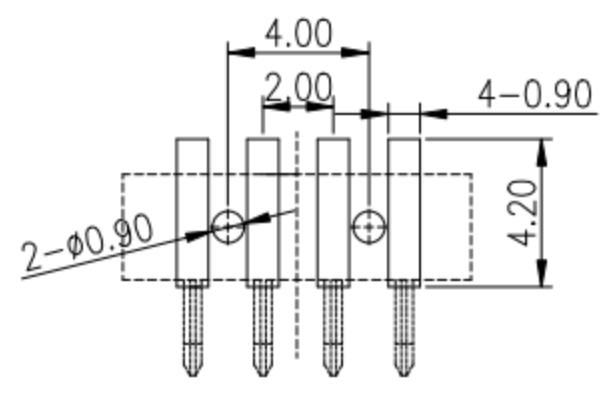
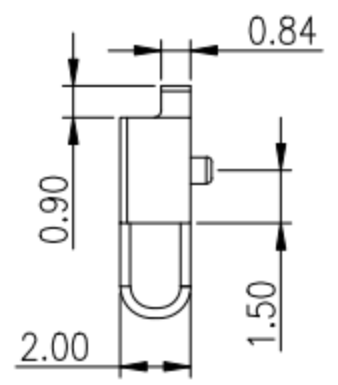
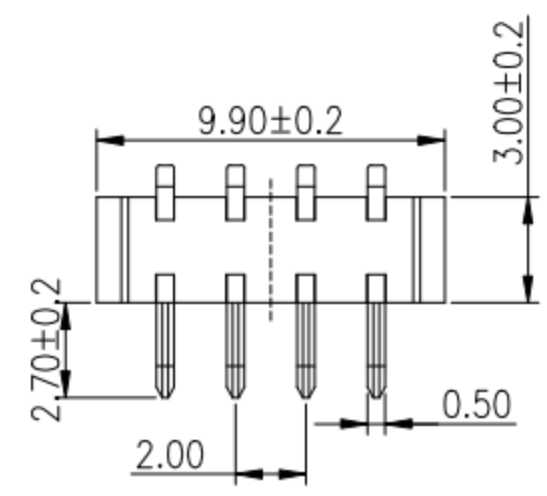
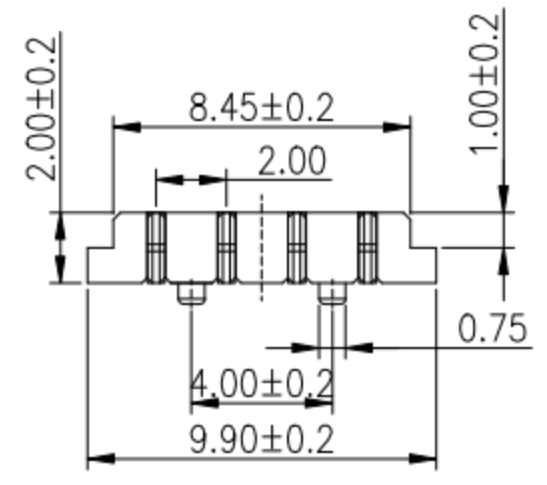
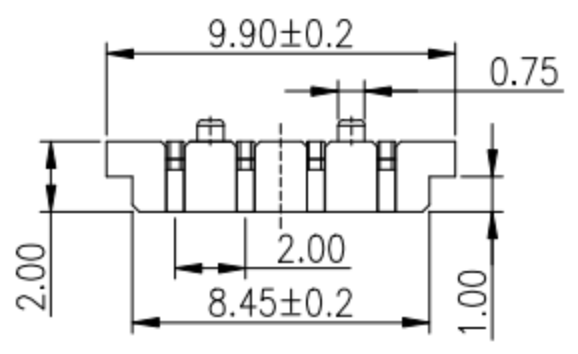

RECOMMENDED P.C.B LAYOUT
TOP VIEW (.XX±0.05)

NOTE:
 Material
 Insulator:Nylon 9T(UL94V-0)
 Contact:phosphor Bronze
 Contact Plated:Gold over Nickel or Tin
 Specification
 Rated voltage: 12V 30V
 Current rating: 3A 5A
 instant CURRENT:7A
 Contact Resistance:30MΩ
 Insulation Resistance:100MΩ
 Dielectric Voltage:1000V
 Operdting Temperature:-40°~105°

②	HOUSING	1	LCP		BLACK
①	CONTACT A	2	PHOSPHOR BRONZE 0.20T	Au PLATED	
ITEM	PART NAME	Q'TY	MATERTAL	DESCRIPTION	REMARK

UNLESS OTHERWISE SPECIFED TOLERANCES					
DECIMALS:			ANGLES:		
DIM	TOL		DIM	TOL	
X.	±0.50		X.	±2'	
X.X	±0.30		X.X	±1'	
X.XX	±0.20		X.XX		
X.XXX	±0.10		X.XXX		

东莞市高迪电子有限公司					
DWG NO.		PART NAME:			
DESIGN:		PART NO.			
CHECK:		REV. UNIT: SHEET:			
APPROVED		A	mm	1/1	